

INSTALLATION METHOD

Art. 113 - 114 - 138

- 1 - Prepare the pipe wrap/fitting by cutting according to the requested diameter of the pipe.
- 2 - Install the first layer of waterproofing membrane and cut a hole in correspondence to the pipe.
- 3 - Heat the surface of the membrane around the protruding pipe and place the flexible collar in position while the surface is still hot in order to ensure the correct attachment to the underside of the flange.
- 4 - Heat a piece of membrane and with the use of a trowel use the molten compound to fill the ribs of the flange.
- 5 - Cut a hole in the membrane corresponding to the diameter of the base of the pipe fitting and proceed with the installation of the second waterproofing layer.
- 6 - Install a stainless steel clamping ring at the top of the pipe fitting.

01.11 PIPE WRAP/FITTINGS IN IGOM.CE

DESCRIPTION FOR SPECIFICATIONS

Art. 113

Supply and installation of ITALPROFILI® pipe wrap/fitting or similar, made from synthetic rubber IGOM CE, suitable for pipes with the following diameters: 34-50-60-75-80-90; with a round ribbed flange. The clamping ring must be in stainless steel.

Art. 114

Supply and installation of ITALPROFILI® pipe wrap/fitting or similar, made from synthetic rubber IGOM CE, suitable for pipes with the following diameters: 75-80-90-100-110-115-125; with a round ribbed flange. The clamping ring must be in stainless steel.

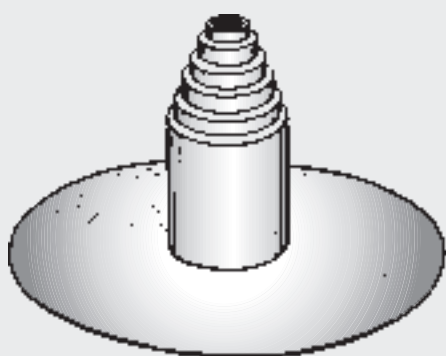

^ ART. 113

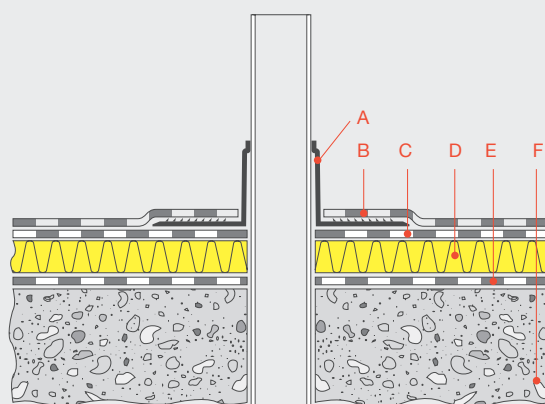

- A - Pipe wrap/fitting
- B - Second layer or piece of bituminous membrane
- C - First layer of bituminous membrane
- D - Insulation
- E - Vapour barrier
- F - Deck

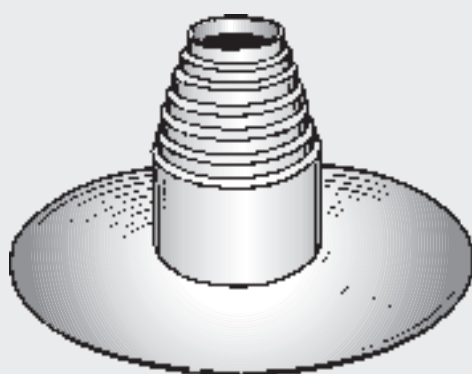

^ ART. 114

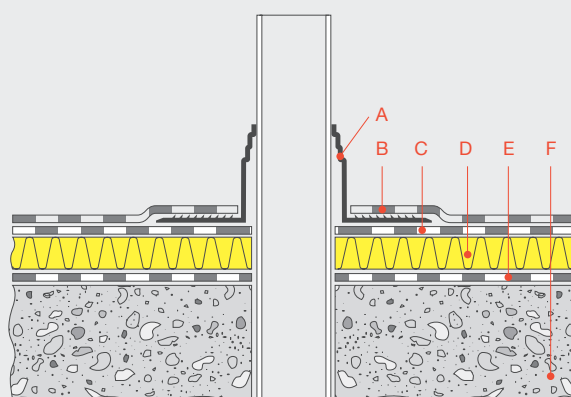

- A - Pipe wrap/fitting
- B - Second layer or piece of bituminous membrane
- C - First layer of bituminous membrane
- D - Insulation
- E - Vapour barrier
- F - Deck

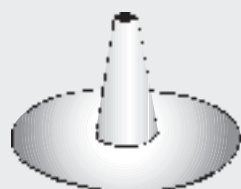

^ ART. 138